



**DOWNLOAD COLOR
INSTALL MANUALS AT
www.bddiesel.com**



GM HD Tie Rod Kit

Upgrade Tie Rods 2001-2019 GM HD Trucks

1032125	2001-2010 GM Tie Rod Kit**
1032124	2011-2019 GM Tie Rod Kit

** 2001-10 requires install of longer sway bar end links (sold separately)

Kit Contents

Kit 1032124	
	
1302124 Tie Rod	FT-58790 Fitting
Qty: 2	Qty: 2

Kit 1032125

1302125 Tie Rod
Qty: 2

Related Parts & Kits

BD Diesel also manufactures kits and replacement parts related to GM Steering assemblies. The following kits and parts are also available for individual purchase.

Kit 1032150	Kit 1032126
	
2001-10 Steering Upgrade Kit	2001-19 Sway Bar End Links

Introduction

2001-2019 GM HD series truck have a Parallelogram steering linkage, containing a center link (or relay rod) attached to pitman and idler arms, and use tie rods to connect the center link to the steering knuckles. This linkage allows for accurate movement of the system and works well for the independent front suspension (IFS) found on GM trucks. However, the systems many links and joints create places for flex and movement, causing toe-in while accelerating in four-wheel drive. To help solve this, the BD Heavy Duty Tie Rods are made with larger diameter shafts for increased strength, and larger inner ball joints for increased wear resistance. This assembly helps hold the wheels straight when experiencing increased loads!

Installation



Secure the vehicle, and ensure it cannot move during install process.

Note: It's highly recommended to have the vehicle aligned after installing new steering components.

Tie Rod Removal

Remove the nut retaining the outer stud into the steering knuckle, and remove outer stud from knuckle.

Note: ball joint puller may be required.

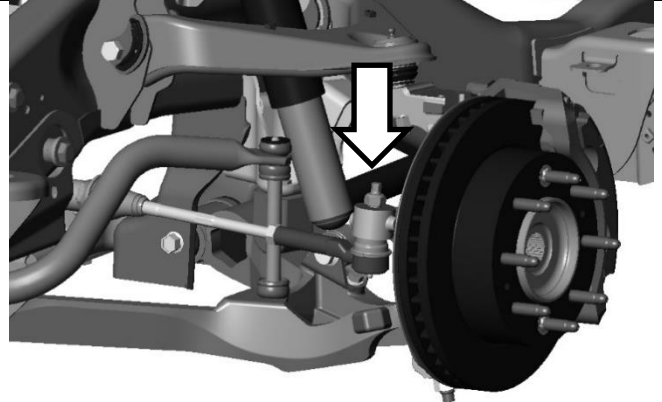

Unscrew inner tie rod from center link by unscrewing inner ball joint.

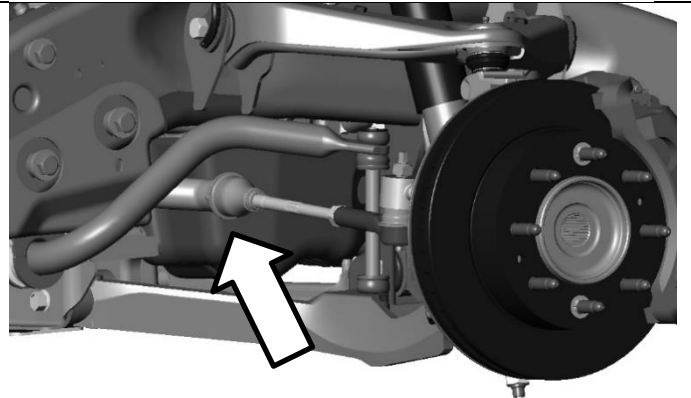

If installing on 2001-10:

Remove sway bar end link by removing upper nut (arrow shown). Slide out bolt from below lower control arm.

Caution: Bushings and spacer tube will become loose and fall when bolt is removed.

Note: Replace sway bar end links with longer units like BD1302126.

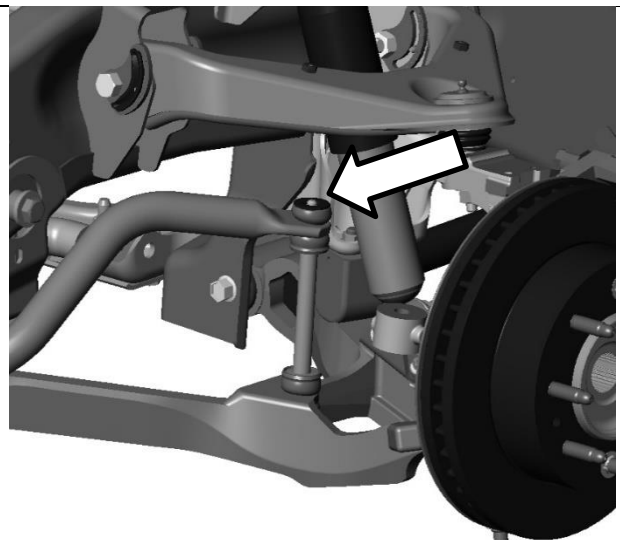

Repeat the above steps for removing the tie rod and sway bar end link on the opposite side of the vehicle.

Tie Rod Install

Note: 2011+ Model year trucks do not have grease fittings for inner ball joints. The 1032124 kit includes two self-threading grease fittings for optional install. For install, see *Grease Fitting Install* section at the end of this manual. Then complete the following steps.

Measure the length of the tie rods removed from the vehicle, and record the values.

Set the length of the BD Tie Rod to the same value as the removed old tie rods. Tighten the jam nut hand tight.

Note This will setup the steering to be close to the old dimensions. Allowing the vehicle to be driven safely until an alignment can be completed.

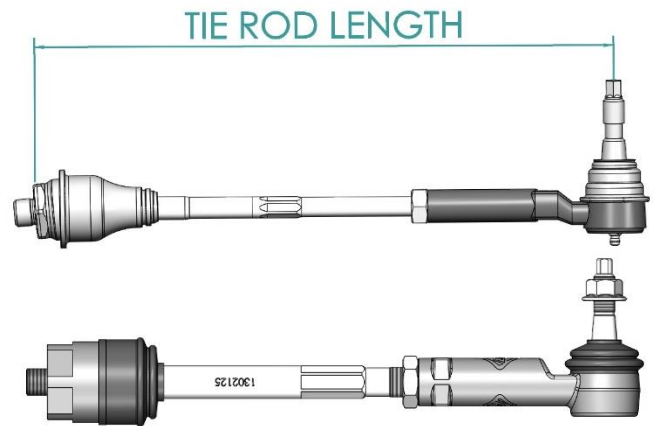

Install the inner tie rod onto the BD Center Link by threading into the link and tightening to spec.

Torque Spec: 2001-10: 74 ft-lbs
2011+: 81 ft-lbs

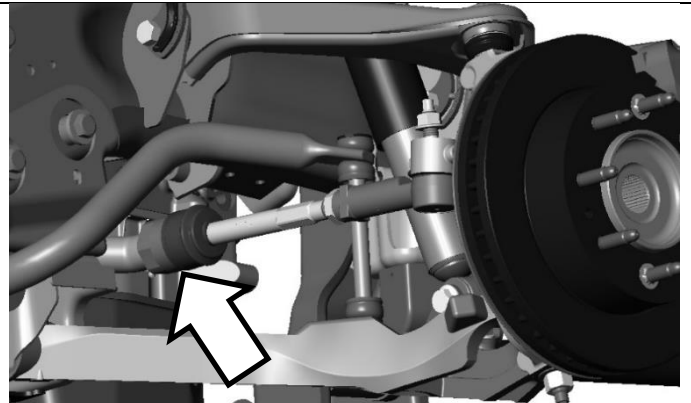

Slip outer tie rod stud into steering knuckle from below, and torque nut to specification.

Torque Spec: All years: 48 ft-lbs

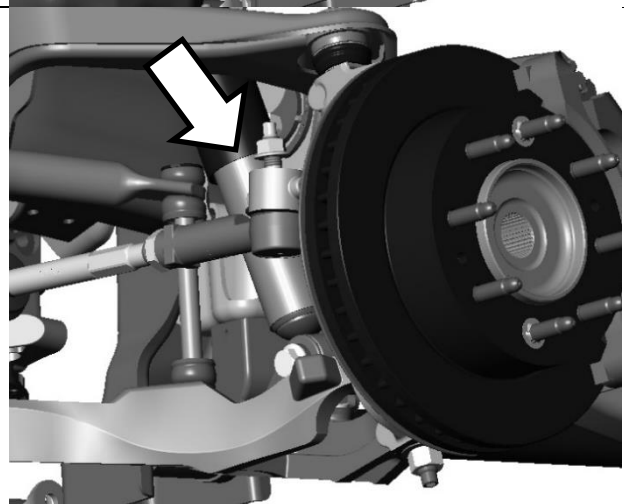

Ensure the tie rods remain near the length set earlier, and tighten the adjustment jam nut.

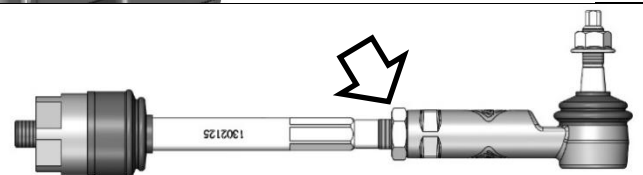

If installing on 2001-10:

Install sway bar end link by installing a bushing onto the bolt, and inserting into the lower control arm from below. Stack bushings and spacer tube as shown, finishing with the nut on top.

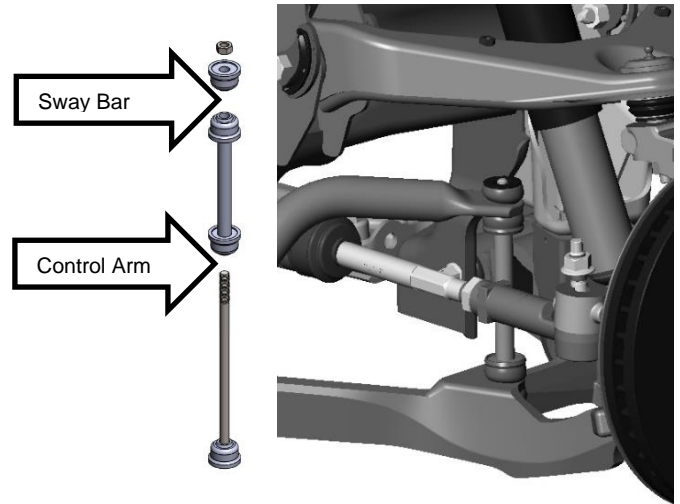

Repeat the above steps for installing the other tie rod and sway bar end link on the opposite side of the vehicle.



Ensure all nuts are tightened to specification, and grease all joints in the steering assembly.

Installation is now complete, and the vehicle is now ready for a wheel alignment.

Grease Fitting Install for 2011+ MY (*Optional*)

Note: 2011+ Model year trucks do not have grease fittings for inner ball joints. The following describes how to install supplied fittings.

Measure .75" (3/4") from tie rod end of bar, and Drill .234" hole (15/64 bit).

Note: It Can be helpful to drill 1/8" starter hole first.

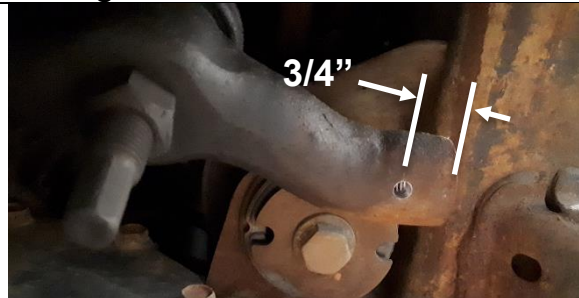

Insert supplied fitting, taking care to ensure it is straight in drilled hole. Thread in until it's fully seated against bar.

Note: Blow out any shavings, and clear threads.



Complete this procedure on both sides of the center link. Once complete, continue with tie rod installation.

